

CGCL-1

product specifications

Commercial Grade Water Chiller

Get luxurious chilled drinking water throughout the entire home with the Everpure Commercial Grade Water Chiller. The perfect complement to an Everpure commercial grade water filtration system, the CGCL-1 chills water to an ideal 50°F. This truly commercial grade unit delivers up to 1.3 gallons of refreshing chilled water per hour and is ideal for drinking, baking, iced tea, lemonade and much more. Despite its ample water-chilling power, the CGCL-1 only consumes 155 watts of electricity.

Combine with commercial grade water filtration

The Everpure CGCL-1 Water Chiller features:

- > Proven commercial-grade quality
- > Chills to an ideal temperature of 50°F
- > 1.3 gallons chilled water per hour
- > Compact unit is easy to hide in any kitchen cabinet or wet bar
- > 0.7 gallon internal tank
- > Whisper-quiet, hermetically sealed, and maintenance-free compressor.
- > Uses ozone-friendly HFC-134a refrigerant
- > Consumes only 155 watts of electricity when compressor is cycling
- > Stainless steel components and lead-free design
- > Accessory power cord included
- > UL listed
- > Use with an Everpure Commercial Grade Water Filtration System or Reverse Osmosis System and an Everpure designer drinking water faucet



It's water filtration you can trust

The same commercial quality that makes Everpure the overwhelming choice for water filtration in restaurants is also available for your home. Everpure's exclusive precoat filtration technology combines Micro-Pure and a unique pleated filter membrane to reduce particles as small as 0.5 microns. This highly engineered design offers the largest filtering surface area, longer life and consistent performance.



EVERPURE
WATER YOU CAN TRUST®

CGCL-1

Commercial Grade Water Chiller

CGCL-1 Commercial Grade Water Chiller – Part No. EV9318-30

Features

- > True commercial grade quality, delivering up to 1.3 gallons of chilled water per hour.
- > Watering system utilizes stainless steel components and completely lead free materials.
- > Cabinet constructed of rust-resistant, galvanized steel.
- > Motor compressor is sealed in lifetime oil supply.
- > Condenser is fan cooled and motor is permanently lubricated.
- > Stainless steel tank is fully insulated.

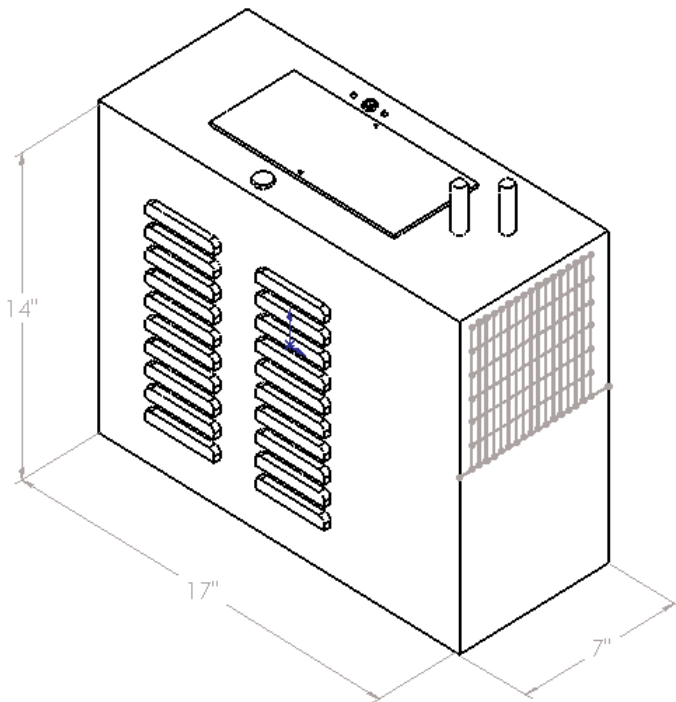

General Installation/Operation/Maintenance Requirements

- > Measures 14" high x 7" wide x 17" deep.
- > Adjustable thermostat is factory pre-set. Requires no adjustment other than for altitude requirements.
- > Install in well-ventilated cabinet.

Model Number	Base Rate	Inlet Water Temp (°F)	GPH of 50°F Drinking Water				Watts Rated	Full Load Amps	Ship Wt. Lbs.
			Room Temperature °F						
			70	80	90	100			
CGCL1	1.3	70	2.1	2.0	1.8	1.6	155	1.7	37
		80	1.5	1.4	1.3	1.2			
		90	1.1	1.0	.9	.8			

Rated watts shown are based on operational (run) time, in accordance with ARI Standards 1010 conditions. Specific applications will determine the actual watts consumed per hour. Watts consumed will be based on number of people served per hour (usage), ambient temperatures, and inlet water temperature.



This water chiller is classified by Underwriters Laboratories Inc. in accordance with NSF/ANSI 61-2002e.

Everpure®, Micro-Pure® and the silver canister color are registered trademarks of Everpure, LLC ©2005

capacity

1.3 gallons per hour

temperature output

50°F (based on 80°F inlet water and 90°F ambient)

tank volume

0.7 gallons

inlet/outlet

1/4" O.D. tubes

power

155 watts; 1.7 amps

motor compressor

1/8 HP, 115 VAC, 60Hz single phase

everpure warranty

The CGCL-1 water chiller has a 5-year limited warranty on the refrigeration system of the unit. Electrical components and water system are warranted for 12 months from date of installation. Warranty pertains to drinking water applications only. Non-drinking water applications are not covered under warranty. A detailed warranty statement is included with each unit.

Everpure, LLC
 1040 Muirfield Drive
 Hanover Park, IL 60133 USA
 Phone: (630) 307-3000
 FAX: (630) 307-3030
 Customer Service: (800) 323-7873
 Technical Service: (800) 942-1153
www.everpure.com

