

Dual Temp Faucet

product specifications

Designer Series

Everpure Designer series dual temperature hot/cold drinking water faucets deliver cold or ambient filtered water and near boiling instant hot water from a single spout. Exclusively designed to be used with the Everpure Commercial Grade Instant Hot Water Dispenser (Solaria™) and other vented instant hot systems, these faucets are equipped with a built-in safety feature with spring loaded shut off to prevent accidents. The cold side may be connected to the Everpure Commercial Grade Water Chiller (Polaria™) for refreshingly chilled drinking water or just simply enjoy ambient filtered water from any Everpure Drinking Water System. The Everpure Dual Temperature faucet features solid stainless steel construction and is available in two beautiful finishes, Polished Stainless and Brushed Stainless. They are lead-free and feature a ceramic disc type valve for smooth functionality and lasting durability. Blue and red indicators on the handles distinguish hot and cold sides.



Everpure Designer Hot/Cold Drinking Water Faucets feature:

- > Sleek, dual handle design
- > Selection of two beautiful finishes to match the most popular designer faucets
- > Spring loaded "hot" shut off valve safety feature
- > Insulated heat-resistant spout
- > Exclusively designed to be used with vented instant hot systems
- > 0.5 GPM flow
- > Lead-free
- > Aerator tip provides even, clear stream of filtered water
- > RO compatible with the use of a separate air gap

For commercial grade water filtration

It's water filtration you can trust

The same commercial quality that makes Everpure the overwhelming choice for water filtration in restaurants is also available for your home. Everpure's exclusive precoat filtration technology combines Micro-Pure and a unique pleated filter membrane to reduce particles as small as 0.5 microns. This highly engineered design offers the largest filtering surface area, longer life and consistent performance.

the pure solution

Our products polish water to premium quality so that water is sparkling and free of unwanted tastes and odors. You'll taste the difference in every sip and everything made with water will taste better, too.

the convenient solution

Everpure systems are easily installed using common household tools. Our systems mount under your sink and are plumbed to a separate filter faucet. And cartridge replacement is easy, too — just like changing a light bulb.

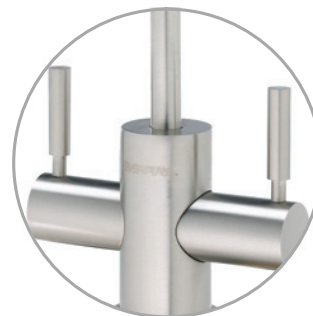

Brushed Stainless Steel

Everpure Dual Temperature Drinking Water Faucets are engineered to be used with:

- Any Everpure Drinking Water Filtration system or Reverse Osmosis System and
- Everpure Solaria™ Instant Hot Dispenser, model CGHE-1 and
- Everpure Polaria™ Water Chiller, model CGCL-1

EVERPURE
WATER YOU CAN TRUST®

Dual Temp Faucet

product specifications

Designer Series

Polished Stainless Steel EV9000-85
Brushed Stainless Steel EV9000-86

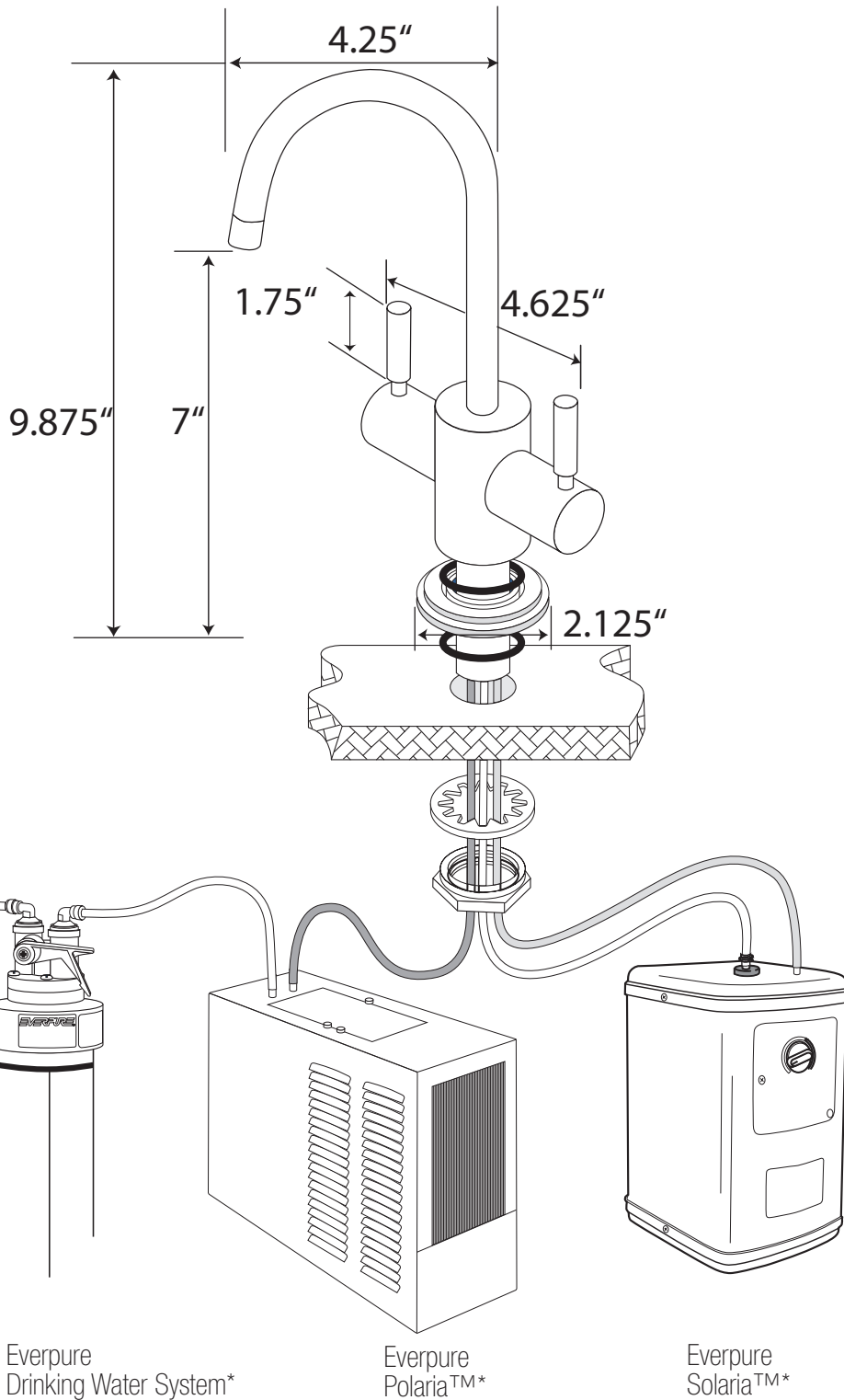

flow rate

0.5 gal./min. (1.9L/min.)

operating pressure

20 to 90 psi

temperature

50 to 212 °F (10 to 100 °C)

installation

1" or standard sink hole installation

everpure warranty

This faucet is warrant to be free and clear of defect and workmanship defect for 5 years. The coated finish is warranted for 3 years. After 3 years, depending on local water conditions and/or cleaning agents used, the coating may not be as bright as new. For general cleaning, use a soft damp cloth. The use of cleaning chemicals is not recommended.

Everpure
Drinking Water System*

Everpure
Polaria™*

Everpure
Solaria™*

*All products sold separately

Everpure® is a registered trademark of Everpure, LLC ©2008

Everpure, LLC
1040 Muirfield Drive
Hanover Park, IL 60133 USA
Phone: (630) 307-3000
Fax: (630) 307-3030
Customer Service: (800) 323-7873
Technical Service: (800) 942-1153
www.everpure.com

EVERPURE
WATER YOU CAN TRUST®